

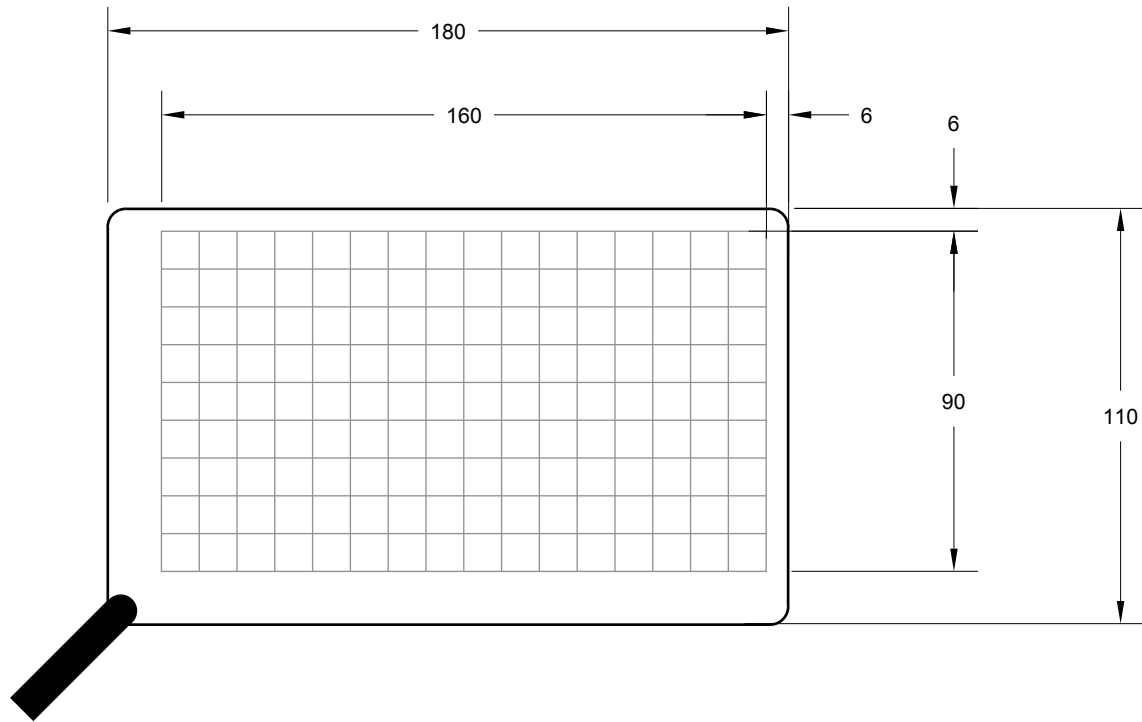

SENSOR SPECIFICATIONS	
SENSOR TYPE	STRETCHABLE TACTARRAY
ARRAY SIZE	9x16
SENSING ELEMENTS	144
ELEMENT SIZE	10mm x 10mm
FULL SCALE PRESSURE RANGE	5, 10, 15, 20psi
CABLE LENGTH	1.5m

REVISIONS			
REV	DESCRIPTION	DATE	APPV
01	INITIAL RELEASE	06.01.11	HT

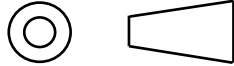

UNLESS OTHERWISE SPECIFIED: DIMENSIONS ARE IN MILLIMETERS TOLERANCES ARE:  DECIMALS      ANGLES .X ± 0.5        ± 1° .XX ± 0.05	APPROVALS		DATE	 Pressure Profile Systems, Inc 5757 Century Blvd, Suite 600 Los Angeles, CA 90045	
	DRAWN	ML	06.01.11		
	CHECKED				
	ENGR				
	QA				
APVD			TITLE		
THIRD ANGLE PROJECTION				<b>STA, 9x16, 10mm</b>	
MATERIAL:					
FINISH					
THIS DOCUMENT CONTAINS INFORMATION PROPRIETARY TO PRESSURE PROFILE SYSTEMS, INC. NEITHER THIS DOCUMENT NOR ITS CONTENTS MAY BE REPRODUCED, USED OR DESCRIBED TO ANY THIRD PARTY IN WHOLE OR IN PART WITHOUT THE WRITTEN PERMISSION OF PRESSURE PROFILE SYSTEMS, INC.	NEXT ASSY	USED ON	SCALE: 1:2	DWG. NO. <div style="font-size: 24px; text-align: center;">5230</div>	REV. <div style="font-size: 24px; text-align: center;">01</div>
APPLICATION	DO NOT SCALE DRAWING		SHEET 1 OF 1		

5      4      3      2      1